

TITAN PIR TRANSMITTER LANTERN

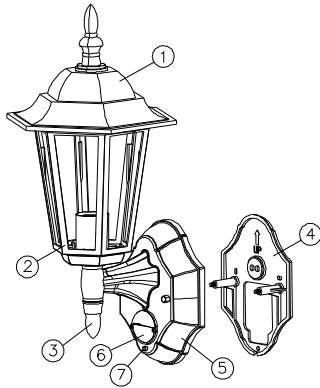

- ① Top Cover
- ② Glass
- ③ TX module
- ④ Back Plate
- ⑤ Front Cover
- ⑥ PIR Sensor
- ⑦ LED

INTRODUCTION

The TITAN PIR TRANSMITTER LANTERN is a unique lighting system for your home or business. At night, the built-in passive infrared (PIR) sensor turns on the LANTERN when it detects a moving heat source in its coverage area. During the day, the built-in photocell sensor saves energy by deactivating the lantern.

The TRS LANTERN TRANSMITTER is compatible with all TRS receivers. Upon a moving heat source being detected, it will illuminate for the length of preset duration and turn on the TRS receivers. After the elapse of the preset duration, it will turn itself and the receivers off.

Note: Read this entire manual before you start to install the system.

SAFETY PRECAUTIONS

- DO NOT install when it is raining.
- Isolate the power supply before installation.
- UK Building Regulations require mains installations be carried out by a qualified electrician.
- BS7671:2001 IEE Wiring Regulations must be complied with in all respects.
- Ensure that the power supply is protected by a 16A circuit breaker or suitable fuse.
- Ensure minimum distance of 0.5m away from lighted objects.
- The unit can be installed only vertically (FIGURE 1a), not horizontally (FIGURE 1b).

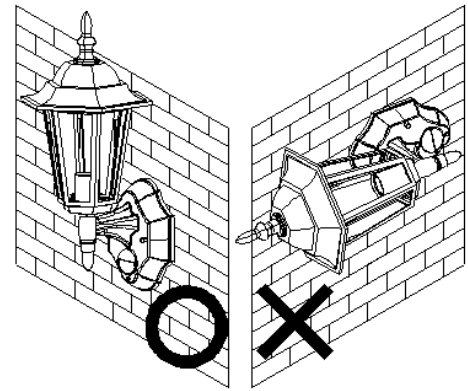

VERTICAL HORIZONTAL
FIGURE 1a & 1b

CHOOSING A MOUNTING LOCATION

- For the best results, mount the Lantern onto normal brickwork, 1.8~2.4m above the ground.
- Installation under eaves is acceptable but radiated and convected heat from the fitting must be taken into account.
- Avoid aiming the PIR sensor at pools, heating vents, air conditioners or objects that may change temperature.
- Avoid pointing the PIR sensor at trees or shrubs or where the movement of pets or animals may be detected.
- Do not allow sunlight to fall directly onto the front of the PIR sensor, otherwise poor triggering response may occur.
- Prior to mounting, keep in mind that the PIR sensor is more sensitive to a heat source moving across its coverage area and less sensitive to a heat source that moves directly towards the PIR sensor (FIGURE 2).

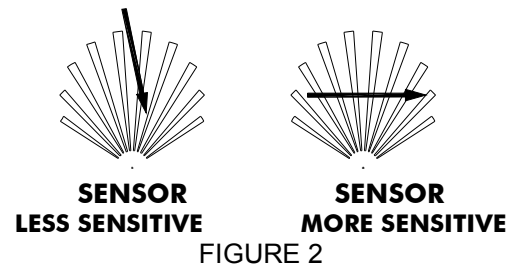

FIGURE 2

LANTERN ASSEMBLY

- (1) Fit the lantern compartment onto the base. (FIGURE 3)

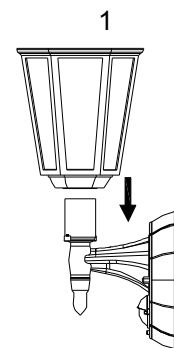

FIGURE 3

- (2) Secure the lantern compartment with the two screws provided. (FIGURE 4)

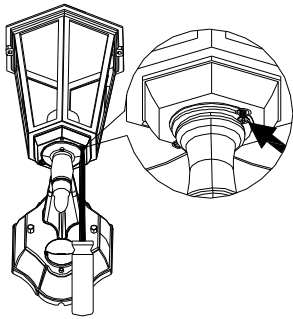

FIGURE 4

LAMP INSTALLATION

- (1) Do not touch the lamp while it is in use or still hot. Allow it to cool off (about 5 minutes) before touching it.
- (2) Do not use the lamp rated higher than 100 watts.
- (3) Switch off the power source. Unscrew retaining screw from the top cover (FIGURE 5).

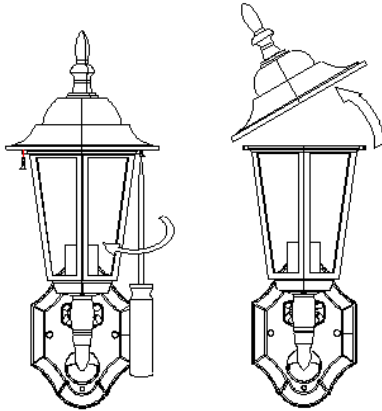

FIGURE 5

- (4) Fit the lamp and screw back the top cover (FIGURE 6).

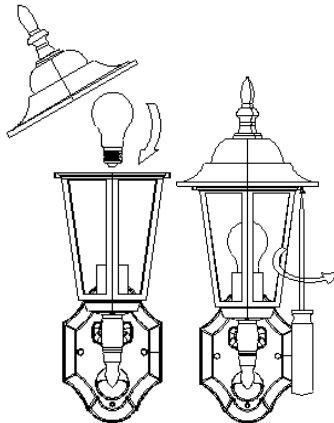

FIGURE 6

2

INSTALLATION

Select a location for the unit based on the coverage angles shown in FIGURE 7a, 7b, 7c.

- For longest detection area, hinge the PIR cover upward (the closed position) FIGURE 7a.

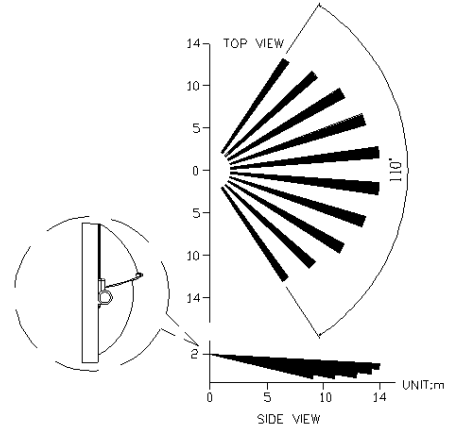

FIGURE 7a

- To restrict the detection area, hinge the PIR cover to the second position FIGURE 7b.

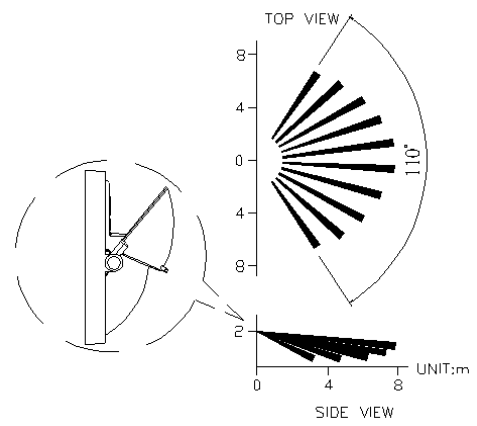

FIGURE 7b

- To restrict the detection area further, hinge the PIR cover to the third position FIGURE 7c.

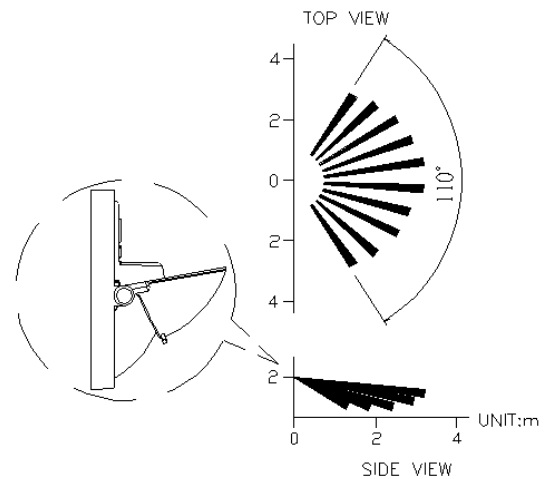

FIGURE 7c

Install a wall switch adjacent to the power source (FIGURE 8). This helps you operate the lantern with ease. See OPERATION for further information.

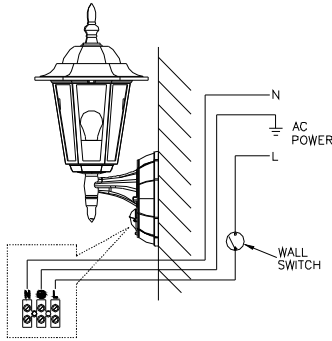

FIGURE 8

WIRING INSTRUCTION

- (1) Switch off the power supply.
- (2) Unscrew the back plate from the front cover. There is a "UP" mark shown on the back plate. Be sure to have the "UP" mark shown pointing up when fixing the back plate onto the wall.
- (3) Use a screwdriver to break a small hole on the cable gasket, enabling the power cord to enter the back plate. (FIGURE 9)

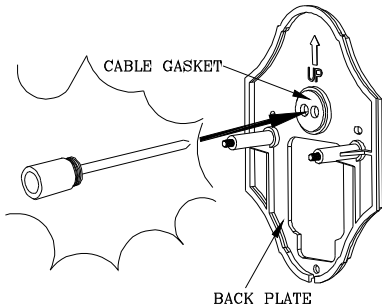

FIGURE 9

- (4) Fix the back plate to the mounting location (FIGURE 10).

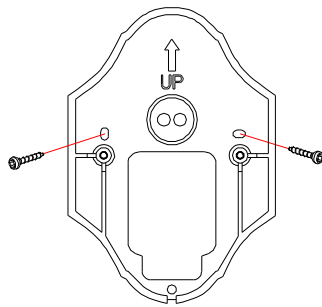

FIGURE 10

- (5) Strip approximately 6-8mm of insulation from the wires on the supply cable.
- (6) Connect the YELLOW/GREEN (Ground wire) to the terminal block "⊖" mark. Connect the BROWN wire (Live wire) to the terminal block "L" mark. Connect the BLUE wire (Neutral wire) to the terminal block "N" mark. (FIGURE 11)

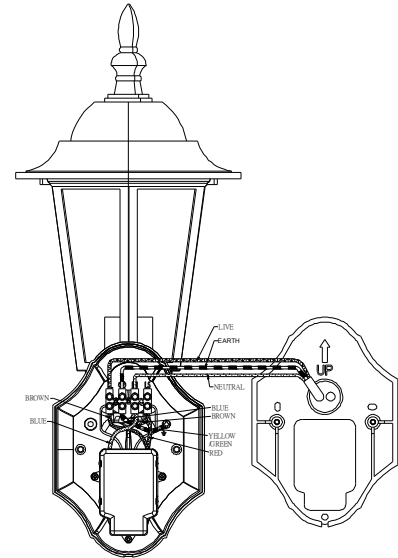

FIGURE 11.

- (7) Place the front cover and secure it with the two screws provided. (FIGURE 12)

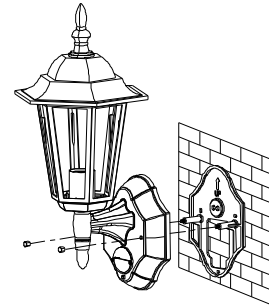

FIGURE 12

SETTING THE LIGHTING SYSTEM

(1) LEARNING THE ID CODE

Note: Prior to emitting the ID code to the receiver, ensure that the associated receiver has entered ID code learning mode. For more details, refer to receiver's operating manual. The lantern transmitter is compatible all TRS receivers within effective radio range (70m approximately).

- a. Turn the Time and Lux controls fully anticlockwise to enter test mode (FIGURE 15)
- b. Activate the transmitter lanterns learning mode press the LED for at least 3 seconds (FIGURE 13) the unit will emit the ID code to the associated receiver(s) During transmission, the LED will illuminate briefly as a notification.

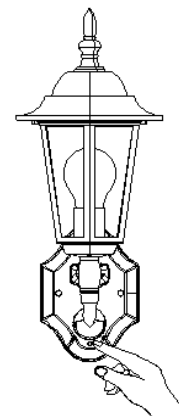

FIGURE 13

- c. Confirm if the associated receiver(s) have learned the ID code successfully.
- d. If code learning is successful, start operating the lantern transmitter.
- e. If not start at step “a” again.

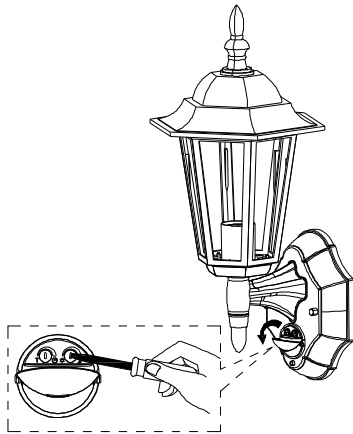

FIGURE 14

(2) TEST MODE

- Turn the LUX control and the TIME control fully anticlockwise – the TEST position. (FIGURE 15)

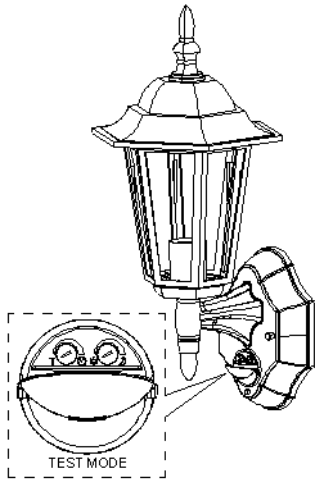

FIGURE 15

- Turn on the wall switch. The lantern will turn on for about 1 minute to warm up. Then it turns off.
- Walk through the detection area. The lantern turns on when you move and turns off after 5 seconds. Wait for the lantern to turn off before moving again to test the sensor.
- Adjust the motion sensor to cover the desired detection area. See Installation for details.

(3) TIME ADJUSTMENT

The TIME adjustment controls how long the Lantern Transmitter stay on if a moving heat source has been detected. Time setting is adjustable from 5 seconds to 12 minutes. (FIGURE 16) When a moving heat source is detected, the Lantern Transmitter switch on and start transmitting until the preset duration expires, the Lantern Transmitter will turn itself and any coded receiver(s) as well.

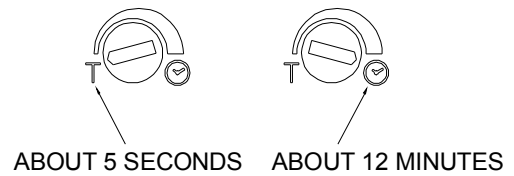

FIGURE 16

(4) LUX ADJUSTMENT

The LUX adjustment determines at what light level the lighting system will start operating when you set the sensor to automatic operation.

Provisionally turn the Motion Sensor LUX control knob fully clockwise to the moon (dusk) position (FIGURE 17). In this provisional setting mode, the Motion Sensor remains inactive during daylight. If this setting is unsatisfactory simply set the LUX control knob to the position that will become active as daylight declines.



FIGURE 17

OPERATION

By using the connected wall switch, you can easily operate the lantern.

(1) AUTOMATIC OPERATION

Turn on the wall switch. The lantern will be on when the sensor detects motion and will be off after expiry of preset duration. The built-in photocell turns the sensor off and on according to the light level selected by the LUX adjustment.

(2) MANUAL OVERRIDE

In Manual Override mode, the lantern will remain on for around 4 ~ 6 hours and will then switch off automatically. Pressing the LED button will activate the manual override, pressing the LED button again will set the unit back to automatic operation mode.

TROUBLE SHOOTING

Code learning unsuccessful:

- Check if wall switch is turned on.
- Make sure the wiring connection is correct.

Light does not turn on:

- Confirm that you have made a correct "wiring connection".
- Make sure that the lamp has not burned out.

PIR detection not working

- Check if wall switch is turned on.
- Make sure that the PIR cover does not block the PIR detection coverage.
- Ensure that PIR detector is not mounted above a radiator or heater or relocate the PIR detector.

SPECIFICATIONS

Power Requirement	AC 230V / 50Hz
Lighting Load	Max. 100W Incandescent
Frequency	433MHz
Transmission Range	70m (in open space)
Detection Angle	Up to 110° at 25° C
Detection Distance	Up to 14m (45.9ft) at 25° C
Mounting Height	Recommended 1.8-2.4m (5.9-7.8ft) Wall Mount
Wall Switch Control	On /Off
LED Button	Code learning & manual override setting
Time Adjustment	5sec. - 12 min.
Lux Adjustment	5-1000 lux
Warm Up Time	About 1 min.
Protection Class	I
Index of Protection	IP44

Specifications subject to change without notice.

Environmental Concerns:

Please DO NOT dispose of electrical appliances as unsorted waste, use the recycling facilities provided by your local authorities.

Please DO NOT dispose of packaging as unsorted waste, use the recycling facilities provided by your local authorities.

