

# TITAN 300W PIR TRANSMITTER FLOODLIGHT

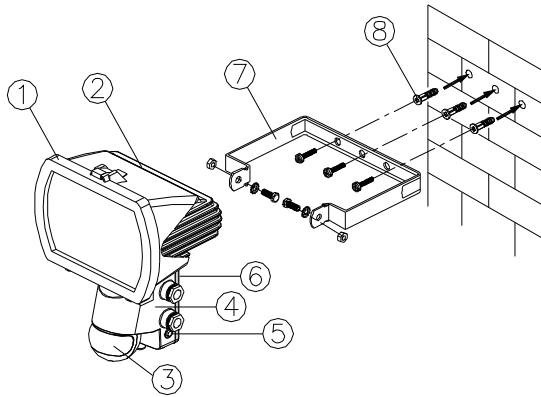

- ① Front Surround
- ② Floodlight
- ③ PIR Sensor
- ④ Wiring Box
- ⑤ Learning Key
- ⑥ Wiring Box Cover
- ⑦ Mounting Bracket
- ⑧ Screw & Plastic Wall Plug

## INTRODUCTION

The TITAN 300W PIR FLOODLIGHT TRANSMITTER is part of a unique lighting system for home or business use. During darkness, the built-in passive infrared (PIR) sensor turns on the FLOODLIGHT and activates the TRANSMITTER when the PIR sensor detects a moving heat source in its coverage area. During daylight, the built-in photocell sensor saves energy by deactivating the FLOODLIGHT. The PIR sensor and TRANSMITTER still remain active.

This FLOODLIGHT TRANSMITTER is compatible with the entire range of TRS receiver products. Upon detection of a moving heat source the unit will transmit for the preset duration and activate any TRS receivers that are in range and coded to accept the TRANSMITTER signal.

**Note:** Please read this entire manual before you start to install the system.

## SAFETY PRECAUTIONS

- DO NOT install when it is raining.
- Isolate the power supply before installation.
- UK Building Regulations require mains installations be carried out by a qualified electrician.
- BS7671:2001 IEE Wiring Regulations must be complied with in all respects.
- HO5RNF round flexible cable and drip loops must be used to avoid water ingress damage to the unit.
- Ensure that the power supply is protected by a 16A circuit breaker or suitable fuse.
- Ensure minimum distance of 0.5m away from lighted objects.
- The unit must be installed vertically (FIGURE 1), NOT horizontally (FIGURE 2).
- DO NOT tilt the floodlight forward more than 45 degrees from the vertical (FIGURE 3).

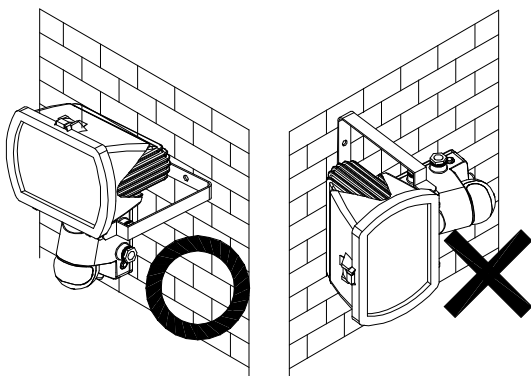

VERTICAL  
FIGURE 1

HORIZONTAL  
FIGURE 2

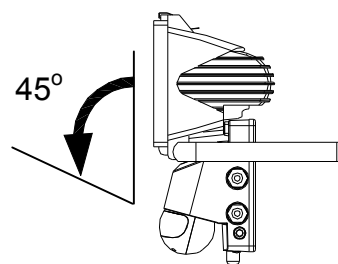

FIGURE 3

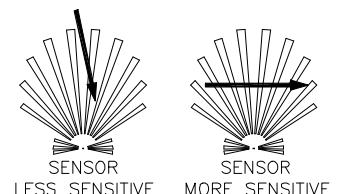

FIGURE 4

## CHOOSING A MOUNTING LOCATION

- For the best results, mount the Floodlight onto normal brickwork, 1.8~2.4m above the ground.
- Installation under eaves is acceptable but radiated and convected heat from the fitting must be taken into account.
- Avoid aiming the PIR sensor at pools, heating vents, air conditioners or objects that may change temperature.
- Avoid pointing the PIR sensor at trees or shrubs or where the movement of pets or animals may be detected.
- Do not allow sunlight to fall directly onto the front of the PIR sensor, otherwise poor triggering response may occur.
- Prior to mounting, keep in mind that the PIR sensor is more sensitive to a heat source moving across its coverage area and less sensitive to a heat source that moves directly towards the PIR sensor (FIGURE 4).

## CHOOSING A MOUNTING LOCATION (Continued)

Select a mounting location for the unit that will give the best results based on the coverage area shown in FIGURE 5.

- To give more control of the coverage area the PIR sensor has an adjustment feature. The PIR sensor can be rotated in its housing approximately 90 degrees horizontally and 45 degrees vertically (FIGURE 6).

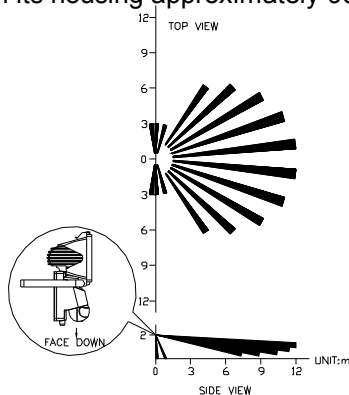

FIGURE 5

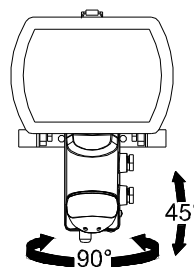

FIGURE 6

## INSTALLATION WIRING INSTRUCTION

- WARNING** isolate the power supply before installation.

It is advisable to install a single pole wall switch (FIGURE 7). This will allow easy control of the floodlight.

1) Undo the four fixing screws from the wiring box cover and remove the cover (FIGURE 8).

2) Unscrew one of the cable glands and using a suitable tool pierce a hole in the cable grommet. Route the HO5RNF supply cable through the cable gland and grommet (FIGURE 9).

3) Strip approximately 6mm of insulation from each of the 3 cores of the supply cable, refer to FIGURE 10.

Connect the BROWN wire (Live wire) to the terminal marked "L".

Connect the BLUE wire (Neutral wire) to the terminal marked "N".

Connect the YELLOW/GREEN (Earth wire) to the terminal block marked  $\frac{\perp}{\text{—}}$ .

An additional lighting load (maximum 1000W incandescent) may be connected to the floodlight using HO5RNF cable:

Connect the BROWN wire (Live wire) of the additional lighting load to the terminal marked "LS".

Connect the BLUE wire (Neutral wire) of the additional lighting load to the terminal marked "N1".

Use the second cable gland for the additional lighting load supply cable.

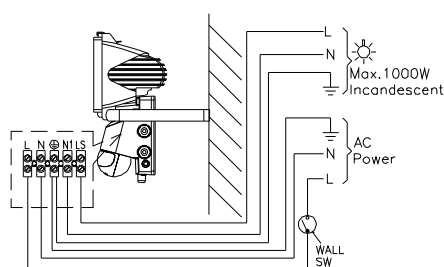

FIGURE 7

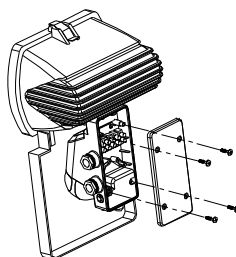

FIGURE 8

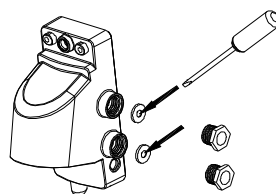

FIGURE 9

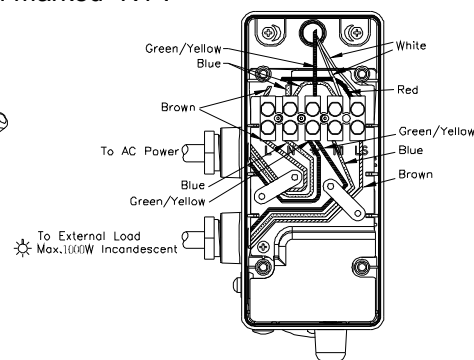

FIGURE 10

4) Remove the mounting bracket from the floodlight. Drill the wall and screw the bracket onto the wall using suitable wall plugs and screws (FIGURE 11).

5) Re-attach the floodlight to the bracket and secure the supply cable (and additional lighting load supply cable if applicable) to the wall using suitable clips. Ensure that the cable is not touching the body of the floodlight, and that there is sufficient slack in the cable to allow the floodlight to be tilted and adjusted as required (FIGURE 12). NB: Tilt and adjust the floodlight by grasping the metal body of the floodlight, not the wiring box.

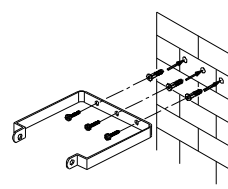

FIGURE 11

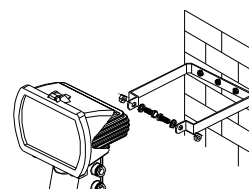

FIGURE 12

## LAMP INSTALLATION

**CAUTION:** DO always handle halogen lamps with a soft clean cloth.  
DO NOT touch the lamp with bare hands as this will dramatically shorten the life of the lamp.  
DO NOT touch the floodlight while it is in use or still hot. Allow it to cool before touching it.  
DO NOT use a halogen lamp rated higher than 300 watts.

- **WARNING** isolate the power supply before installation.

1) Use a flat blade screwdriver to open the front cover clip on the floodlight (FIGURE 13).

2) Pull down the front surround which is mounted on hinges and will swing open (FIGURE 14).

3) Install the lamp by inserting one end into the lamp holder and depressing until enough clearance is gained to seat the other end of the lamp into the lamp holder. Rotate the halogen lamp to ensure proper seating (FIGURE 15).

4) Refit the front surround and secure with the front cover clip (FIGURE 16).

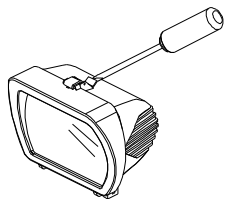

FIGURE 13

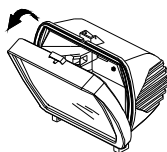

FIGURE 14

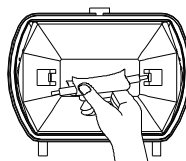

FIGURE 15

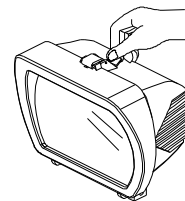

FIGURE 16

## FIRST TIME POWER UP

- Turn the two adjustment screws on the bottom of the floodlight PIR sensor (TIME control and LUX control) fully anticlockwise to the T position (FIGURE 17).



FIGURE 17

- Reinststate the power supply to the floodlight and switch the floodlight on from the wall switch if installed. The floodlight and the led will illuminate to indicate that the floodlight is in 'warm up' mode. After approximately one minute the floodlight and the led indicator will turn off. The floodlight is now in 'test mode'.
- Walk through the PIR sensor coverage area. The floodlight turns on when you move and turns off after approximately five seconds. Wait for the floodlight to turn off before moving again to test the PIR sensor.
- Adjust the PIR sensor to cover the desired detection area. See CHOOSING A MOUNTING LOCATION (FIGURE 5) and (FIGURE 6) for details.

The transmitter floodlight can be used as a single PIR sensor floodlight. But is primarily intended to communicate with and trigger receivers in the TRS range to give a complete security lighting system.

If no TRS receivers are to be installed onto the system go to the TIME ADJUSTMENT section to complete the installation.

If receivers are to be installed onto the system proceed as follows.

1) To set the TRS receiver(s) to receive signals from this floodlight first put the TRS receiver(s) into code learning mode. Refer to the instructions for each type of receiver in order to do this.

2) Once the TRS receiver(s) are in code learning mode, and within range, activate the transmitter floodlight learning mode by pushing and holding the Learning Key button, located on the side of the transmitter floodlight wiring box, for more than three seconds (FIGURE 18). The led on the transmitter floodlight will illuminate whilst you hold in the Learning Key button and then extinguish, release the Learning Key button. The led will flash briefly to indicate transmission is taking place. The transmitter floodlight will continue to transmit the learning code for approximately thirty seconds and then revert back to normal operation.

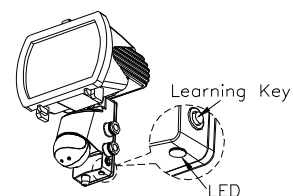

FIGURE 18

3) Now establish if the TRS receiver(s) have learnt the code by walking through the transmitter floodlight PIR sensor coverage area. When the transmitter floodlight turns on the TRS receiver(s) coded to it will also turn on. (NB during daylight TRS receiver floodlights must be in 'test mode'. In order to do this refer to the instructions for the TRS receiver.

- If the TRS receiver(s) have failed to learn the code repeat steps 1), 2) and 3) above.

4) Once the system is functioning as required go to the TIME ADJUSTMENT section to complete the installation.

## TIME ADJUSTMENT

The TIME adjustment (located at the bottom of the PIR sensor) controls how long the transmitter floodlight is operational after being triggered by its PIR sensor. The timer will turn on the floodlights transmitter (and the lamp contained in the floodlight unless overridden by its LUX adjustment control) for the duration set on the TIME adjustment control.

The TIME setting is adjustable from 5 seconds to 12 minutes (FIGURE 19). Set the time according to your personal requirements.

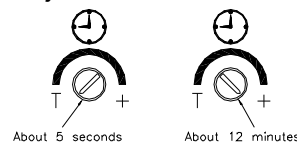

FIGURE 19

TRS receiver(s) coded to the floodlight will also activate and remain on for the same duration (unless overridden by their LUX adjustment control).

## LUX ADJUSTMENT

The LUX adjustment (located at the bottom of the PIR sensor) determines at what light level the transmitter floodlight will start operating.

Provisionally turn the LUX control fully clockwise to the moon symbol (dusk) position (FIGURE 20). At this provisional setting the floodlight remains inactive during daylight, but the floodlight PIR sensor and transmitter remain active. At dusk the floodlight will become active. If this provisional setting proves to be unsuitable the LUX control should be adjusted. Simply set the LUX control to the position you desire the floodlight to become active as daylight declines.



FIGURE 20

## AUTOMATIC CIRCUIT TEST

The transmitter floodlight has an automatic circuit test. This is useful if you experience problems coding TRS receiver(s) or suspect a problem with the transmitter floodlight circuitry or wiring. To activate AUTOMATIC CIRCUIT TEST press and release immediately the Learning Key (FIGURE 18). The led indicator will flash three times and the floodlight will illuminate and remain on until you again press and immediately release the Learning Key. If the transmitter floodlight functions correctly during this test look elsewhere for the problem.

## TROUBLE SHOOTING

Floodlight does not turn on:

- Check if the wall switch is turned on.
- Confirm that you have made the correct wiring connections.
- Make sure that the lamp has not burned out.
- Carry out automatic circuit test.

PIR sensor not working:

- Check if the wall switch is turned on.
- Confirm that you have made the correct wiring connections.
- Ensure that the PIR detector is not mounted above or close to a heat source and not subject to bright sunlight during daylight hours.
- Carry out automatic circuit test.

TRS receivers not responding:

- Check if all wall switch(s) are turned on.
- Check if receiver LUX settings are overriding.
- Make sure all wiring connections are correct.
- Carry out automatic circuit test.

## SPECIFICATIONS

Power Requirement	AC 230/240v 50Hz
TH Lamp Load	Max. 300W TH Halogen Lamp
Additional Lighting Load	1000W Incandescent
Transmitter Frequency	433MHz
Transmission Range	Approx 70m (in open space)
Detection Angle	Up to 110° at 25° C
Detection Distance	Up to 12m (39.3ft) at 25° C
Mounting Height	Recommended 1.8 - 2.4m (5.9 - 7.8ft) Solid Wall Mount
Wall Switch Control	On /Off
Learning Key	Code learning & automatic circuit test
Time Adjustment	5 seconds - 12 minutes
Lux Adjustment	5 - 200 lux
Warm Up Time	Approximately 1 minute
Index of Protection	IP44
<b>Specifications subject to change without notice.</b>	

## Environmental Concerns:

Please DO NOT dispose of electrical appliances as unsorted waste, use the recycling facilities provided by your local authorities.

Please DO NOT dispose of packaging as unsorted waste, use the recycling facilities provided by your local authorities.