

# TITAN DIMMABLE RECEIVER RELAY

## INTRODUCTION

The TITAN Receiver Relay is part of a unique lighting / security system for home or business use. The unit is designed to receive a signal from compatible TITAN transmitters. When triggered the TITAN Receiver Relay will switch a hard-wired load connected to the unit. Maximum switching capacity is 300w incandescent lighting or 70 watts fluorescent lighting or 1 amp maximum load.

Code Button  
&  
Status LED

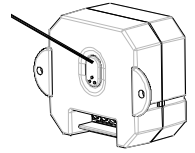

**Note: Please read this entire manual before you start to install the system.**

## SAFETY PRECAUTIONS

- Isolate the power supply before installation.
- UK Building Regulations require mains installations be carried out by a qualified electrician.
- IEE Wiring Regulations must be complied with in all respects.
- Fluorescent lighting is not dimmable. Use dimming facility on incandescent loads only.
- Ensure that a suitable breaker or fuse protects the power supply.

## CHOOSING A MOUNTING LOCATION

- DO NOT fix the unit onto metalwork or within 1m of metalwork (i.e. radiator, water pipes etc) as this could affect the receipt of signals from TITAN transmitters.
- DO NOT locate the unit directly above a heat source (e.g. fire, radiator, boiler etc).
- DO NOT expose the unit to the weather or liquids. The unit is not weather proof.

An IP44 weather proof box is available into which the unit can be mounted. (Quote weather proof box code: TRS04IP)

## WIRING CONNECTIONS

- **WARNING** isolate the power supply before installation.

Refer to FIGURE 1 and connect the unit as follows:

Connect the BROWN wire (Live wire) to the terminal marked "L IN"

Connect the BLUE wire (Neutral wire) to the terminal marked "N IN"

Connect the load Live wire to the terminal marked 

Connect the load Neutral wire to the terminal marked "N OUT"

Note the following:

1) The N IN and N OUT terminals are linked internally within the TITAN relay. Use of the N OUT terminal is therefore optional. However the N IN terminal must be connected to a neutral line to power the TITAN relay.

2) There is no provision for earth  within the TITAN relay. Therefore earth continuity for any loads that require an earth must be ensured using appropriate earth connections external to the TITAN relay.

3) The TITAN relay is rated at 300w incandescent lighting or 70 watts fluorescent lighting or 1 amps maximum load. When establishing the maximum amperage rating of any load that is not incandescent lighting note that most inductive loads draw an increased start up current. In some cases five times greater than their running current. Ensure that the increased start up current does not exceed the maximum 1 amp rating of the TITAN relay.

If in doubt contact the manufacturer of the inductive load to establish the true maximum start up current.

For switching loads larger than the capacity of the TITAN relay an additional mains contactor may be used. Simply use the TITAN relay to switch the coil of the appropriate sized contactor and connect the load to the appropriate terminals of the additional contactor. (Note the dimming facility cannot be used where a contactor is added to the circuit).

4) The TITAN relay has a built in internal antenna that is satisfactory for most installations. However where the TITAN relay will be mounted in a closed void or where signals may be weakened, an external antenna connection terminal is provided.

For best results, and to increase the receiver sensitivity of the TITAN relay, attach 1.5m of 0.5mm<sup>2</sup> single core insulated cable. (0.5mm<sup>2</sup> multi core insulated cable may be used but may not be as effective). This antenna cable should then be stretched out away from the TITAN relay either within the void or if available outside of the void.

Note that if the antenna cable is routed outside into the open atmosphere it is imperative that a 'drip loop' and sealant is used to avoid rainwater running along the antenna entering the void area and damaging the TITAN relay.

## FIRST TIME POWER UP and CODE LEARNING

The TITAN relay is capable of holding up to twelve TITAN transmitter codes. On first time power up no codes will be stored. To indicate this the Status LED will flash on and off. Note that it is necessary to program in the transmitter codes prior to final fixing of the TITAN relay.

To enable the TITAN relay to memorise compatible TITAN transmitter codes proceed as follows:

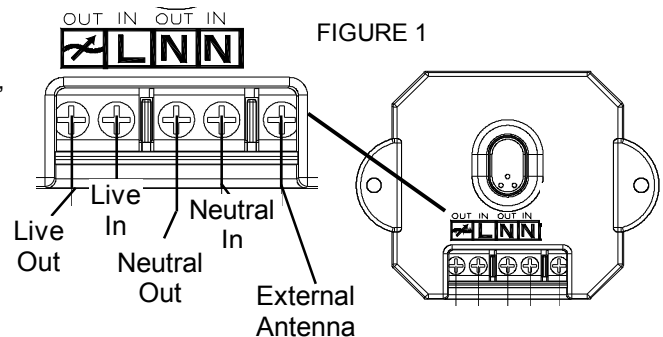

## FIRST TIME POWER UP and CODE LEARNING (Continued)

- Reinstall the power supply to the TITAN relay. The Status LED on the TITAN relay will flash on and off continuously to indicate that no codes are installed in the TITAN relay memory.

1) Activate the TITAN relay-learning mode by pushing and holding in the TITAN relay code button for more than three seconds. The LED on the TITAN relay will illuminate whilst you hold in the code button and then extinguish, release the relay code button. The LED will flash briefly to indicate the receiver is in learning mode. The receiver will remain in learning mode for approximately thirty seconds or until a code is received and learnt.

2) Once the receiver is in learning mode activate the learning mode for the TRS transmitter you wish the receiver to learn from. Refer to the instructions for each type of transmitter in order to do this. During learning mode the TRS transmitter should be no less than 30cms and no more than the maximum range of 70m from the receiver.

3) The LED on the TITAN relay will stop flashing, illuminate for approximately three seconds and then go off. This indicates that the TITAN relay receiver has learnt the code.

4) Confirm that the TITAN relay has correctly learnt the code by activating the relevant transmitter to trigger the TITAN relay on. Where you wish to test multiple triggers from TRS transmitters the Manual Off function on the TITAN relay may be useful. Once the TITAN relay has been triggered on to operate the Manual Off function simply press and release the code button on the TITAN relay. This will switch off the TITAN relay and make it ready to receive the next trigger signal.

- If the TITAN relay receiver has failed to learn the code repeat steps 1), 2), 3) and 4) above.

Repeat steps 1), 2), 3) and 4) above for each transmitter you wish the receiver to learn from. Up to the maximum of twelve separate transmitters.

- If you make an error during the code learning sequence, or you wish to clear the memory of the TITAN relay for another reason proceed as follows:

5) Activate the TITAN relay-learning mode by pushing and holding in the code button for more than three seconds. The LED on the TITAN relay will illuminate whilst you hold in the code button and then extinguish, release the code button. The LED will flash briefly to indicate the receiver is in learning mode.

6) Immediately push and hold in the code button again for more than five seconds. The LED on the TITAN relay will illuminate whilst you hold in the code button and then extinguish, release the Learning Key button. The LED on the TITAN relay will flash on and off continuously to indicate that the memory has been cleared and no codes are installed in the TITAN relay memory.

- When coding is complete fix the TITAN relay to an appropriate surface using appropriate screws through the two mounting lugs provided on the TITAN relay.
- The TITAN relay is designed to be hard wired. The UK Building Regulations require hard-wired mains installations be carried out by a qualified electrician.
- All appropriate legislation and regulations must be applied when installing this unit.

## DIMMING

The TITAN relay can only be dimmed using the TITAN Remote Control Transmitter. Switch on the relay using the on button (top left of the TITAN Remote Control Transmitter). Then press and release the same on button again. The relay will enter the dimming cycle. Once the desired dimming level is achieved press and release the same on button again. The relay will then hold this dimming level. To re-start the dimming cycle press and release the same on button again. To switch the relay off use the off button top right of TITAN Remote Control Transmitter. Note: Providing the mains input is maintained to the relay the unit will retain the last dimming level stored before the relay was switched off with the TITAN Remote Control Transmitter.

### TROUBLE SHOOTING

Relay does not trigger:

- Check the power supply is turned on.
- Confirm that you have made the correct wiring connections.
- Ensure transmitter is working and within range.
- Clear the relay memory and repeat the code learning sequence again.

### SPECIFICATIONS

Power Requirement	AC 230/240v 50Hz
Switching Capacity	300w incandescent lighting or 70 watts fluorescent lighting or 1 amp maximum load
Receiver Frequency	433MHz
Code Button	Code learning, clearance of memory, manual off, status LED
Warm Up Time	Approximately 1 minute
Index of Protection	IP21
<i>Specifications subject to change without notice.</i>	

### Environmental Concerns:

Please DO NOT dispose of electrical appliances as unsorted waste, use the recycling facilities provided by your local authorities.

Please DO NOT dispose of packaging as unsorted waste, use the recycling facilities provided by your local authorities.

